

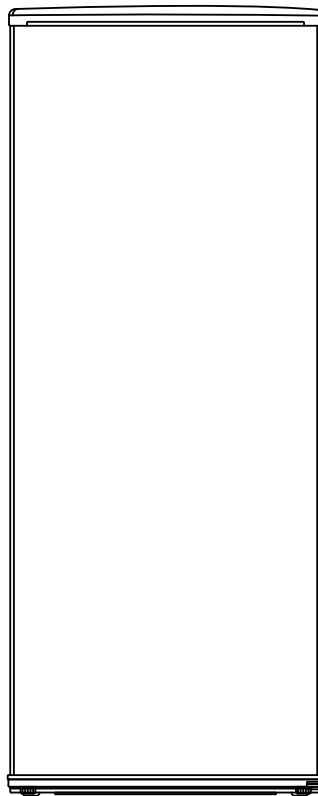

INSTRUCTION MANUAL

REFRIGERATOR

RF/140



Read before application and keep the introductions cautiously.

Made in China for Hypermart Ltd

IMPORTANT SAFETY INSTRUCTIONS

WARNING

To reduce the risk of fire, electrical shock, or injury when using your refrigerator, follow these basic precautions:

◆Read all instructions before using the refrigerator.

– **WARNING:** This appliance is not intended for use by persons (including children) with reduced physical, sensory or mental capabilities, or lack of experience and knowledge, unless they have been given supervision or instruction concerning use of the appliance by a person responsible for their safety.

Children should be supervised to ensure that they do not play with the appliance.

– **WARNING:** Keep ventilation openings, in the appliance enclosure or in the built-in structure, clear of obstruction.

– **WARNING:** Do not use mechanical devices or other means to accelerate the defrosting process, other than those recommended by the manufacturer.

– **WARNING:** Do not damage the refrigerant circuit.

– **WARNING:** Do not use electrical appliances inside the food storage compartments of the appliance, unless they are of the type recommended by the manufacturer.

◆Do not store explosive substances such as aerosol cans with a flammable propellant in this appliance.

– **WARNING:** When positioning the appliance, ensure the supply cord is not trapped or damaged.

– **WARNING:** Do not locate multiple portable socket-outlets or portable power supplies at the rear of the appliance.



WARNING! FLAMMABLE MATERIAL!

◆**WARNING: Risk of child entrapment.**

◆This appliance should not be used by children aged 8 years and above or persons with reduced physical, sensory or mental capabilities or lack of experience and knowledge unless they are supervised or instructed concerning use of the appliance in a safe way and they understand the hazards involved.

◆Children should be supervised to ensure that they do not play with the appliance.

◆Cleaning and user maintenance must not be performed by children without supervision. Children aged from 3 to 8 years are allowed to load and unload refrigerating appliances.

◆To avoid the possibility of child entrapment; please take the following precautions before disposing of the refrigerator.

- Remove all doors from the unit.
- Leave the shelves in place so that children cannot easily climb inside.

◆This appliance is intended to be used in household and similar situations such as

- Staff kitchen areas in shops, offices and other working environments;
- Farm houses and by clients in hotels, motels and other residential-type environments;
- Bed-and-breakfast environments;
- Catering and similar non-retail applications.

-Save these instructions-

WARNING

This refrigerator should be properly grounded for your safety. The power cord of this refrigerator is equipped with a three-prong plug which is compatible with standard three-prong wall outlets to minimise the possibility of electrical shock.

This refrigerator requires a standard 220-240V/50Hz electrical outlet with three-prong grounded socket.

Do not, under any circumstances, cut or remove the third ground prong from the power cord supplied.

Improper use of the grounded plug can result in the risk of electrical shock.

This refrigerator is not designed to be used with an inverter.

The cord should be secured behind the refrigerator and not left exposed or dangling, so as to prevent accidental injury.

Never unplug the refrigerator by pulling the power cord. Always grip the plug firmly and pull straight out from the socket.

Do not use an extension cable with this appliance. If the power cord is too short, have a qualified electrician or service technician install an outlet near the appliance. Use of an extension cord can negatively affect the performance of the unit.

- **WARNING:** If the supply cord is damaged, it must be replaced by the manufacturer, its service agent or similarly qualified persons in order to avoid a hazard.

FIGURE:

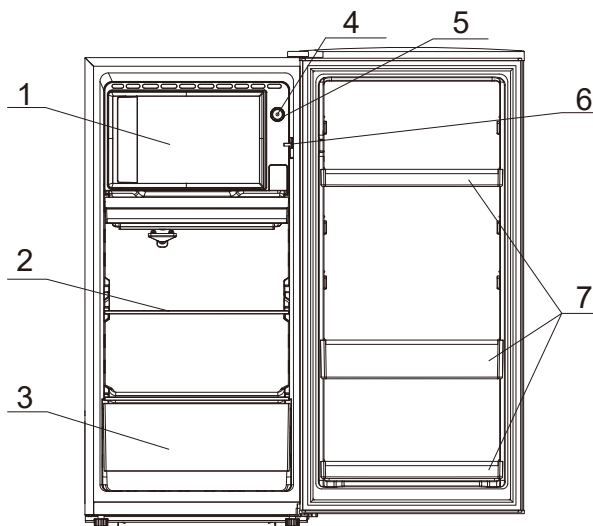

- | | | | |
|---------------------------|----------------|----------------|----------------------|
| 1. Ice-making compartment | 2. Shelf | 3. Crisper | 4. Defrosting button |
| 5. Knob | 6. Lamp switch | 7. Bottle rack | |

DEFROSTING YOUR UNIT :

Defrost the unit when the frost accumulated on the evaporator is about 5mm thick.

Simply press the DEFROST button in the middle of the temperature control knob, the

refrigerator will then begin to defrost. Once the defrost cycle has completed, the refrigerator will return to normal operation automatically. During the defrost cycle, the ice melts into the water drip tray. To remove the water, either remove the water drip tray and/or place a collection container under the tray. Use a sponge or towel to pick up the melting ice off the unit floor. Dry the water collection tray and place back under the chiller compartment. Defrosting usually takes a few hours. To defrost quickly remove all foods from the unit and leave the door open. Never use a knife or other metal instrument to scrape ice/frost from the evaporator.

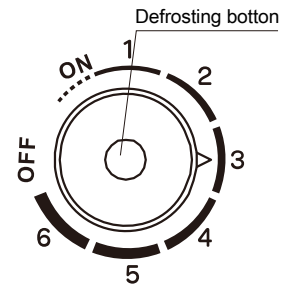

INSTALLATION METHOD:

1. The ground should be level, solid and dry.
2. Avoid placing upside down or horizontally. The angle should be not more than 45° between the cabinet and the ground if inclination is necessary.
3. Leave a space of 30cm above the refrigerator and 5cm on either side and behind the refrigerator, otherwise air will not be able to circulate properly, reducing the freezing effect, and increasing energy consumption.
4. Place your refrigerator in a space where there is less humidity, so as to improve electronic insulation and avoid rust.
5. Avoid placing the refrigerator near heat sources (stove, warmer etc.) or in direct sunlight.

HOW TO USE THE REFRIGERATOR:

1. When operating the refrigerator for the first time, leave the empty refrigerator to operate until it stops, which will usually take 2-3 hours (10 hours in summer), then adjust the thermostat knob.
2. Install the accessories in the appropriate positions according to the diagram.
3. Turn the thermostat dial to between 3 and 4; insert the power plug into the socket.
4. Pour cooled boiled water into the ice tray up to the water level line. Put the ice tray into the evaporator. Turn the thermostat dial to 7 above the ice tray. Ice takes 2 - 3 hours to form. Slightly rotate the ice tray when removing the ice.
5. Defrosting is needed when the frost layer on the evaporator reaches 3 - 4mm. First, disconnect from the power supply, then open the door, take out the ice tray and all food. The refrigerator will begin to defrost. Wipe and dry the evaporator after defrosting has finished. Then return the food to its place.

Attention!

1. When storing food, wrap it in plastic wrap or store it in a container with a lid; this prevents odours and keeps it dry. Opening the door for long periods can cause a significant increase of the temperature in the compartments of the appliance.

2. There should be sufficient space between each item of food; do not store too much food.

3. To save electricity, do not open the door too frequently.

Clean regularly surfaces that can come in contact with food and accessible drainage systems.

4. Store raw meat and fish in suitable containers in the refrigerator, so that it is not in contact with or drip onto other food.

5. If the refrigerating appliance is left empty for long periods, switch off, defrost, clean, dry, and leave the door open to prevent mould developing within the appliance.

6. The temperature inside can be lower if take out the drip tray during performance testing.

MAINTENANCE

1. Periodical maintenance may prolong the refrigerator's life. For safety reasons, the power cord must be disconnected before maintenance.

2. Abrasive powder, detergent powder, sodium carbonate, benzene, petrol, acid alcohol hot water etc. must not be used to clean the refrigerator; these may damage the paint coat and the plastic.

Safety inspection after maintenance

1. Power wire: broken or not?

2. Power plug: hot abnormal or not?

3. Power plug: plug properly inserted or not?

| Problem | Check: |
|-------------------------------------|---|
| No refrigeration | Is there an interruption to the power supply? Is the voltage sufficient? Has the fuse blown? |
| Refrigerating effect insufficient | Is the thermostat in the proper position? Is there sufficient space around the appliance? Is the door being opened too frequently? Is the appliance exposed to direct sunlight or too close to heat sources? Is too much food being stored or is the temperature of food stored too high? |
| Food frozen inside the refrigerator | Is the thermostat in the proper position? Is too much food being stored? |
| Unusual noises | Is the appliance positioned on a flat surface? Is the appliance in contact with other items? |
| Compressor in constant operation | Is too much food being stored? Is the door not closed tightly or being opened too frequently? |

Replacing illuminating lamp :

Disconnect the power supply before replacing the illuminating lamp.

Remove the used bulb by rotating anticlockwise.

Insert the new bulb by rotating clockwise (the bulb should be a screw bulb of less than 15W).

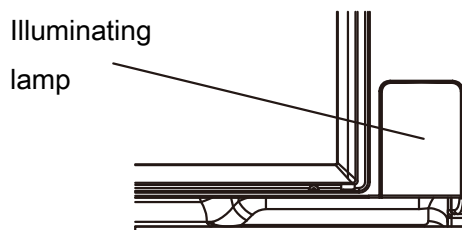

Main technical data:

| | |
|--|-------------------------------------|
| Model | RF/140 |
| Climate Type | ST/T |
| Electrical Shock Protect Mode | I |
| Total Net Capacity (L) | 180 |
| Rated Voltage (VAC) | 220-240 |
| Rated Frequency (Hz) | 50 |
| Rated Current (A) | 0.8 |
| Max. Lamp's Rated Power (W) | 15 |
| Annual Energy Consumption (kWh/y) | 345 |
| Refrigerant | R600a |
| Refrigerant Weight(g) | 38 |
| Vesicant | C ₅ H ₁₀ (CP) |
| Net Weight (kg) | 31 |
| Noise dB (A) | 39 |
| Overall Dimension(mm) [Width Depth Height] | 525*543*1301 |

Notice:

All data covered by this catalogue are given as general information only; our company reserves the right to change or modify its product line without prior notices.

Circuit diagram:

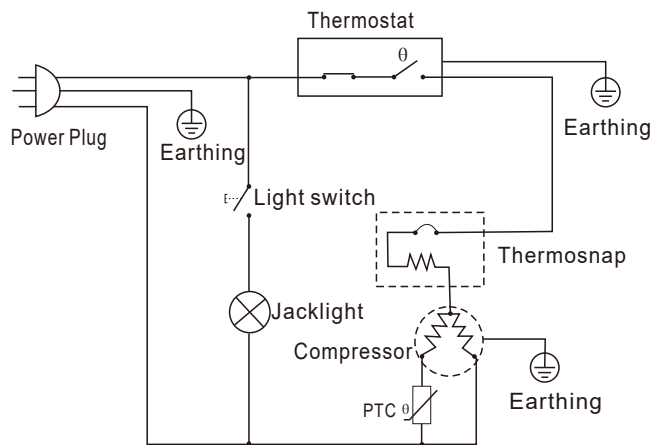

Packing list:

| No. | Name of parts | RF/140 |
|-----|--------------------|--------|
| 1 | Water tray | 1 |
| 2 | Refrigerator Shelf | 3 |
| 3 | Door seal | 1 |
| 4 | Bottle guard | 3 |
| 5 | Instruction manual | 1 |

Correct disposal of this product:



This marking indicates that this product should not be disposed of with other household wastes throughout the EU. To prevent possible harm to the environment or human health from uncontrolled waste disposal, recycle it responsibly to promote the sustainable reuse of material resources. To return your used device, please use the return and collection systems or contact the retailer where the product was purchased. They can take this product for environmental safe recycling.

说明书技术要求(此页不印刷)

大小：A5

材质：105g铜版纸

存货编码：306042180000012