

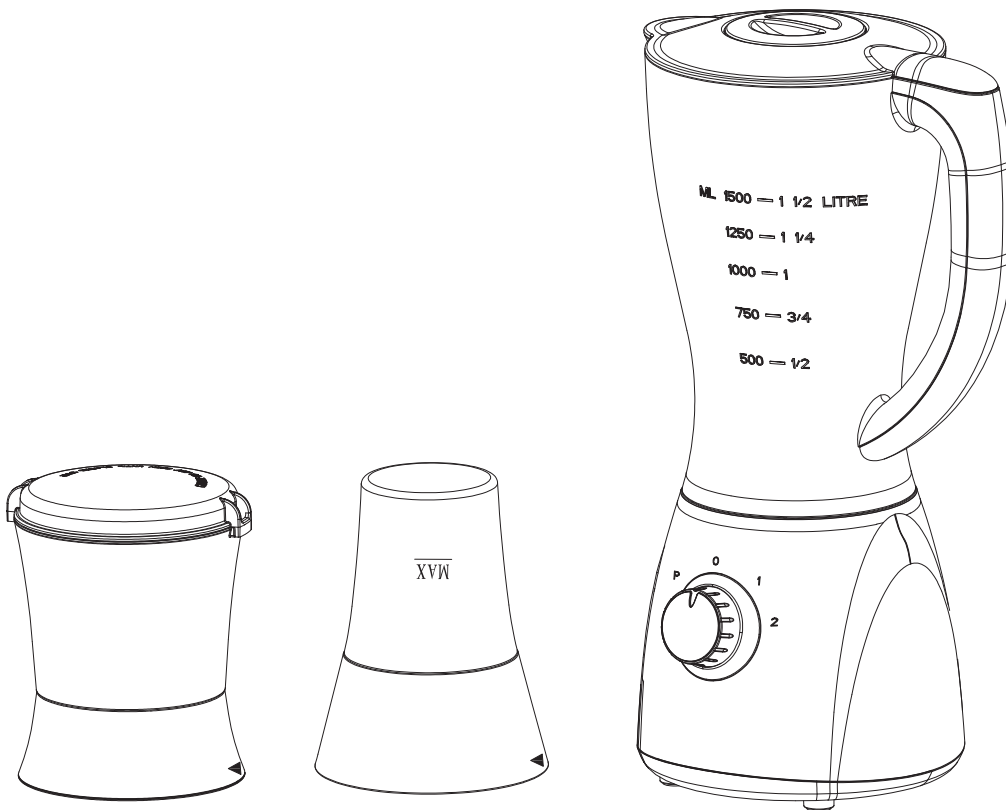

STAND BLENDER

INSTRUCTION MANUAL



MODEL: RM/368

Read this booklet thoroughly before using and save it for future reference

IMPORTANT SAFEGUARDS

When using this electrical appliance, basic safety precautions should always be followed, including the following:

1. Read all instructions.
2. Before using check that the voltage indicated on the product corresponds with the voltage of your electrical outlet.
3. Do not let cord hang on hot surface or over edge of table or counter.
4. Do not operate any appliance with a damaged cord or plug or after the appliance malfunction or has been damaged in any manner. Return the appliance to the nearest authorized service facility for examination, repair or adjustment.
5. If the supply cord is damaged , it must be replaced by the manufacturer or its service agent or a similarly qualified person in order to avoid a hazard.
6. Close supervision is necessary when any appliance is used by or near children.
7. Avoid contacting the moving parts.
8. Keep hands and utensils out of container while blending to reduce the risk of severe injury to persons or damage to the blender. A scraper may be used but must be used only when the blender is not running.
9. The use of attachments not recommended or sold by manufacturer may cause fire, electric shock or injury.
10. Unplug from outlet when not in use, before putting on or

taking off parts, and before cleaning. To disconnect, turn any control to “off”, then remove plug from wall outlet by grasping the plug, not the cord.

11. To reduce the risk of injury, never place blade assembly on motor unit without the jar properly attached.
12. This appliance is not intended for use by persons (including children) with reduced physical, sensory or mental capabilities, or lack of experience and knowledge, unless they have been given supervision or instruction concerning use of the appliances by a person responsible for their safety.
13. Children should be supervised to ensure that they do not play with the appliance.
14. Do not leave the machine on unattended.
15. When removing the blender from the motor unit, wait until the blades have completely stopped.
16. Always operate blender with cover in place.
17. Always use the appliance on a secure, dry level surface.
18. Never place this appliance on or near a hot gas or an electric burner or where it could touch a heated appliance.
19. Do not use outdoors.
20. *Do not use appliance for other than its intended use.*

HOUSEHOLD USE ONLY

KNOW YOUR BLENDER

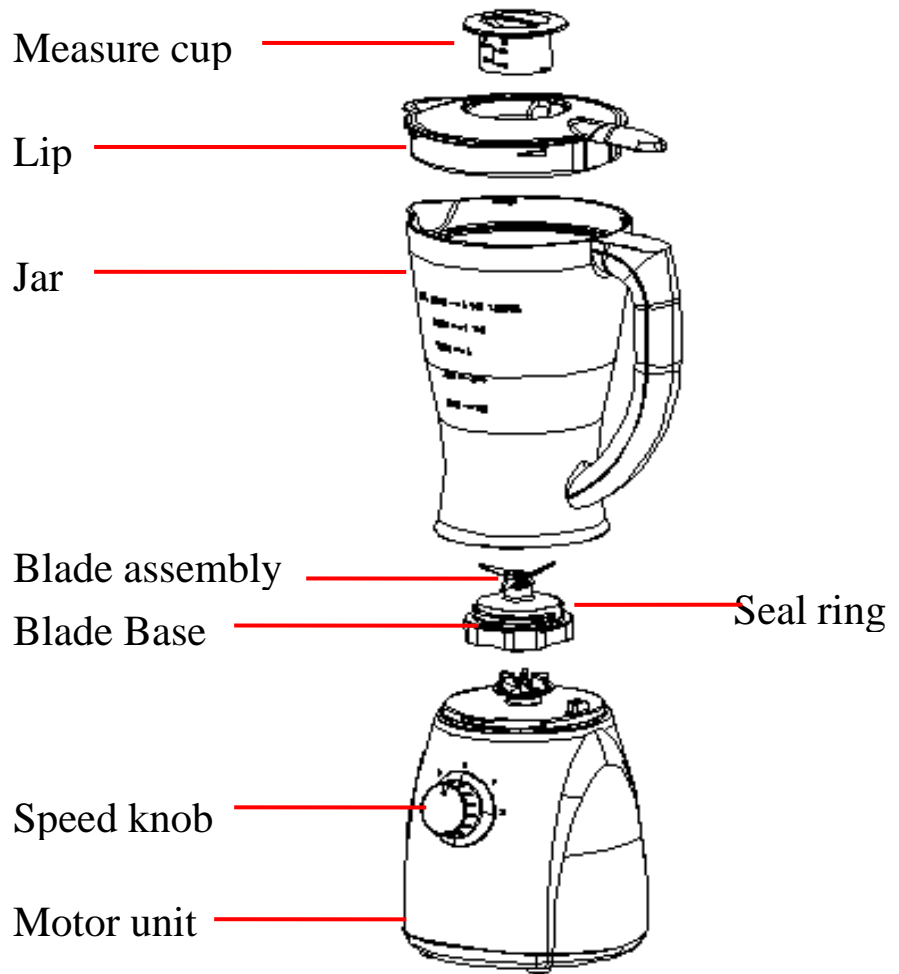
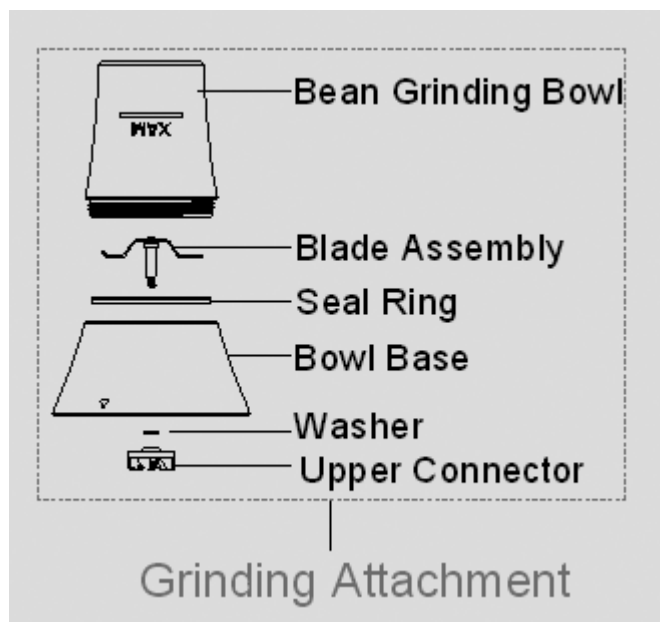
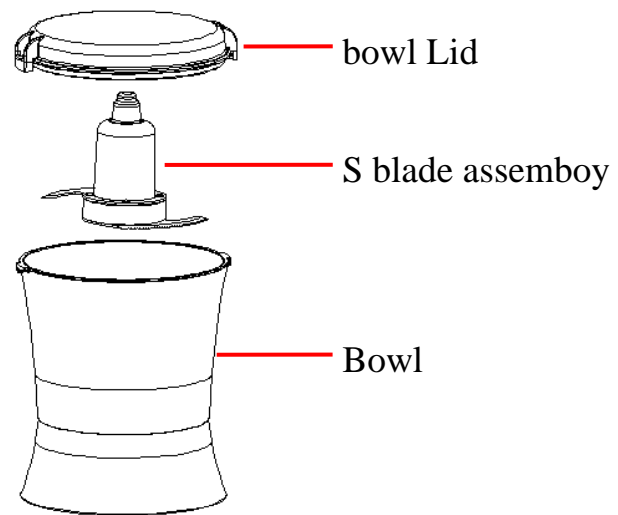

Fig.1





CHOPPER_BOWL

SPEED KNOB

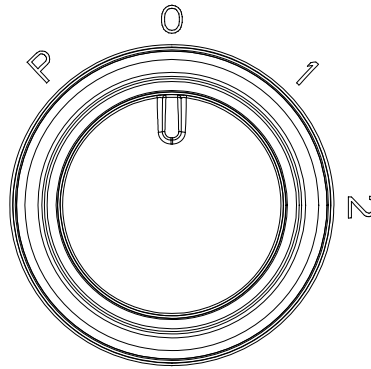

Fig.2

HOW TO USE

Before initial use

1. Before first use, unpack the appliance and place all parts on a horizontal surface.
2. The jar assembly (including the measure cup, lid, seal ring 1, jar, seal ring 2 , blade assembly and jar base) has already been assembled into the motor unit. Disassemble to wash all detachable parts except the motor unit. Refer to the latter chapter CARE AND CLEANING.

3. Once all pieces have been cleaned and dry thoroughly, reassemble.

1) Invert the jar onto a level surface, holding the jar handle, put the the seal ring 2 and blade assembly onto the jar base bottom and secure the blade assembly by turning it anti-clockwise until tight (See Fig.3)

2) Reposition the jar assembly with its opening upwards. Wrap the seal ring 1 around the lid bottom and put the lid onto the jar assembly. Place the measure cup exactly into the lid by fitting the small projection on the both sides of the cup into the slots of the lid and turning the cup clockwise until tight. (See Fig.4)

3) Finally, place the assembled jar onto the motor unit by aligning the strip on the assembled jar bottom. (See Fig.5)

CAUSION: Jar and jar base is now secure. Do not try to twist the jar and jar base onto motor unit

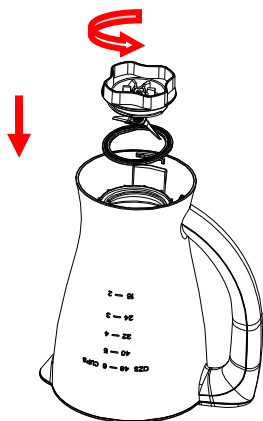

Fig.3

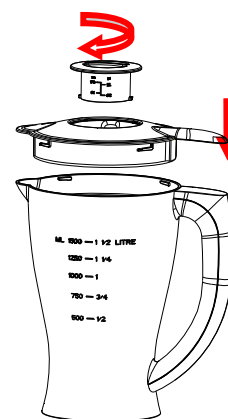

Fig.4

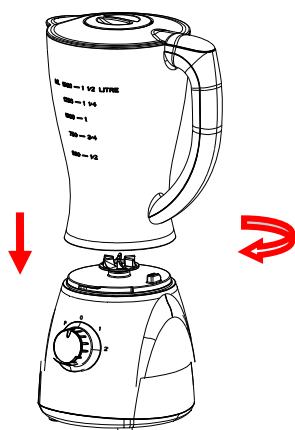

Fig.5

How to use

1. Peeled or cored the fruit or vegetables and then cut it into small dices.
2. Place the food to be blended into the jar (See Fig.6) . Usually, certain amount of purified water has to be added to facilitate the smooth running of appliance. The proportion of the food and water is 2:3.The amount of mixture should not exceed the max level as indicated on the jar.

RECIPE

FOOD TYPE	SPEC	WEIGHT	SPEED
Carrot (apple, pear etc.)	Cut into 15mm*15mm*15mm	Carrot: 600g Water: 900g	High speed

Note: never use boiling liquids or run the appliance empty.

3. Put the lid on the jar. Be sure the measuring cup is in place.
4. Plug the power cord into a standard wall outlet.
5. Turn the speed knob to the appropriate speed setting for your task.
6. For quick or delicate blending tasks, turn the speed knob to P position and hold for a few seconds and then release, the knob will reset to O position automatically. Operate several times until the consistence you want is obtained
7. If you want to add ingredients while the blender is working, remove the measuring cup and place through the lid opening. (See Fig.7)
8. When crushing ice or hard food, keep one hand firmly on the lid.

9. When the consistence you desire is obtained, turn the knob to O position.

Note: 1) For each use, the consecutive operation time should not exceed 3 minutes. at least 10 minutes rest time must be maintained between two continuous cycles, let the unit cool to room temperature before performing next operation cycle.

2) If you want to stop the machine during operation, turn the knob to O position anytime.

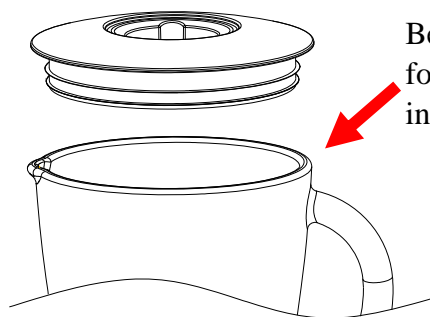

Fig.6

Before blending, add food to be blended into the jar.

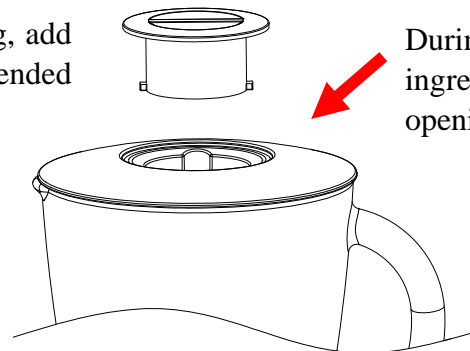

Fig.7

During blending, add the ingredient through the lid opening.

Important operating tips

10.Fill the grinding bowl with proper bean (such as coffee bean), then assemble the grinding blade assembly and grinding bowl together. Please see.

NOTE:

1. Do not run the appliance for more than 3 minutes per time, and only wait until the unit is cooled to room temperature before performing next operation cycles.
2. The quantity of bean to be allowed to grind by the grinding bowl is Max 35g, and the finished time is about 30s.
3. Then place the prepared chopping food into the bowl.The food must be cut into small size firstly(such as 2cm*2cm*6cm for beef).
4. The appliance allows you to chop the maximum quantity of beef or

meat is 150g. Select the highest speed and operate for 40S。

- For best circulation of food that are to be blended with some liquid, pour the liquid into the jar first, then add solids.
- Some of the tasks that cannot be performed efficiently with a blender are: beating egg whites, whipping cream, mashing potatoes, grinding meat, mixing dough, extracting juice from fruit and vegetable
- The following items should never be placed in the unit as they may cause damage: bones, large pieces of solid, frozen food, or tough foods such as turnips.
- To crush ice, add up to 6 ice cubes. If more ice is needed, remove the cup and add cubes one by one through the lid opening.

CARE AND CLEANING

This product contains no user serviceable parts. Refer service to qualified service personnel.

1. Before cleaning, unplug the blender.
2. Always wash immediately after use for easier cleaning. Don't let food dry on the jar assembly as this will make cleaning difficult.
3. Pour a little warm soapy water into the jar and turn the knob to P position for a few seconds. And then empty the jar.
4. Dismantle all detachable parts. Lift the jar assembly off the motor unit, To detach the blade assembly by turning it clockwise from the jar base bottom , and remove the seal ring 2 and blade assembly (see fig.8). In addition, detach the jar cover seal ring 1 from the jar

cover.

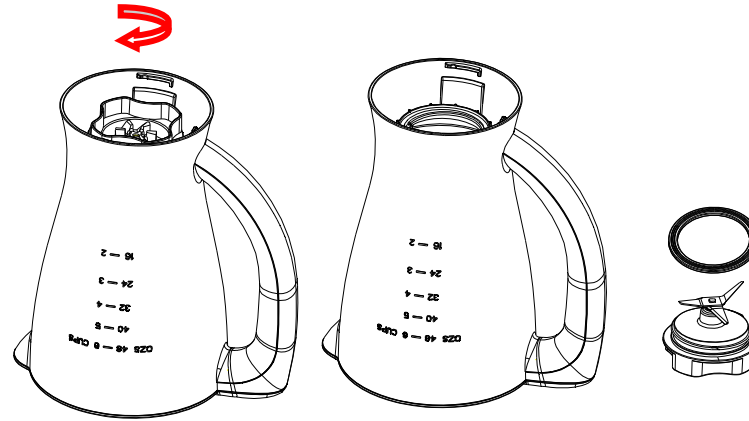

Fig.8

5. Rinse the measure cup, lid, seal ring 1, jar, seal ring 2 and blade assembly by hands or in a dishwasher and then dry. They are dishwasher safe components, but the temperature setting shall not exceed 70°C.
6. Brush the blade clean using warm soapy water, then rinse thoroughly under the tap. Don't touch the sharp blades, handle carefully. **Don't immerse the blade assembly in water.** Leave to dry upside down away from children.
7. Wipe the motor unit with a damp cloth and dry thoroughly. Remove the stubborn spots by rubbing with non-abrasive cleaner. If liquids spill into the motor unit; first unplug the unit, then wipe with a damp cloth and dry thoroughly.

CAUTION:

- 1) **Do not immerse the motor unit in liquid to prevent the risk of electric shock.**
- 2) **Do not use rough scouring pads or cleansers on parts or finish.**

ENVIRONMENT FRIENDLY DISPOSAL



You can help protect the environment!
Please remember to respect the local regulations: hand in the non-working electrical equipments to an appropriate waste disposal centre.